

**ASIAN SCHOOL OF MANAGEMENT
&
TECHNOLOGY**

Gongabu, Kathmandu, Nepal



PREPARED BY:

Hari Rijal

Exam Roll No.: 7822/17

T.U. Registration No.: 7-2-1181-61-2017

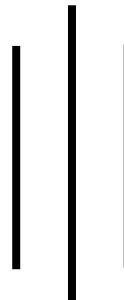

*Software Project Management Lab Report Based on Precedence Network Diagram and
Gantt Chart*

Submitted to

Faculty of Management, Tribhuvan University

in partial fulfillment of the requirements for the degree of

Bachelor of Information Management

Internal Examiner:

Name: Surya Bam

Signature:

Date:

External Examiner:

Name:

Signature

Date

What is a Precedence Diagram Method?

Precedence Diagram Method (PDM) is a visual representation technique that depicts the activities involved in a project. It is a method of constructing a project schedule network diagram that uses boxes/nodes to represent activities and connects them with arrows that show the dependencies.

Purpose of Precedence Diagram Method (PDM)

The Program Evaluation and Review Technique (PERT) and Critical Path Method (CPM) techniques are essentially limited to “finish-start” relationships (i.e., activity B cannot start until activity A is completed). PDM was developed subsequent to the PERT/CPM techniques and its function is to permit a more accurate depiction of relationships among various activities.

How is the Precedence Diagram Method (PDM) Depicted?

The Precedence Diagram is depicted by a chart with nodes and their relationships. An arrow connects two nodes to represent an active relationship. It's also called a nodal diagram or network diagram.

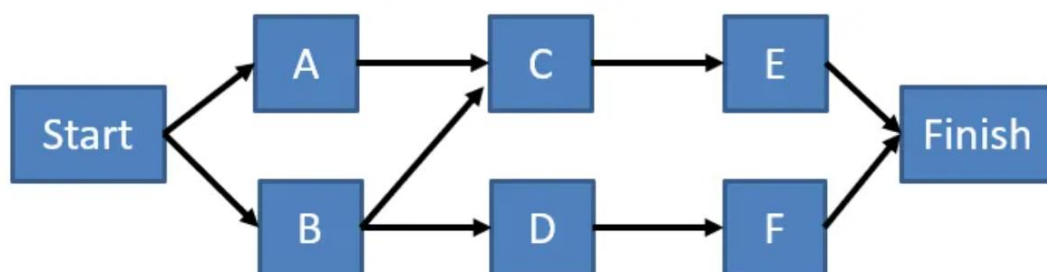

Figure: Precedence Diagram Method (PDM)

The Four Precedence Diagram Methods (PDM)

The PDM has four ways of developing the diagram. These methods are:

- **Finish-Start:** In this dependency, an activity cannot start before a previous activity has ended. This is the most commonly used dependency.
- **Start-Start:** In this dependency, there is a defined relationship between the start of activities.
- **Finish-Finish:** In this dependency, there is a defined relationship between the end dates of activities.

- **Start-Finish:** In this dependency, there is a defined relationship between the start of one activity and the end date of a successor activity. This dependency is rarely used.

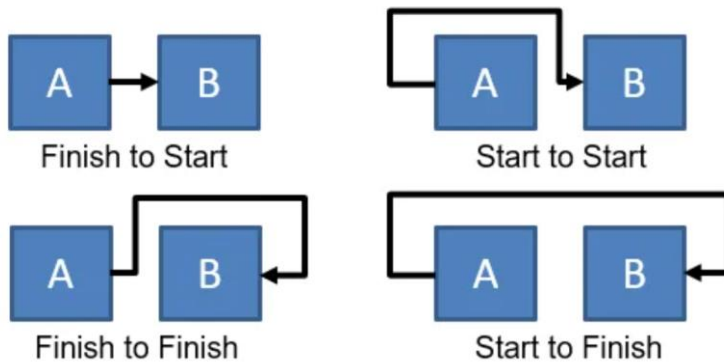

What is a Gantt Chart?

A Gantt Chart is a horizontal bar chart developed as a production control tool in 1917 by Henry L. Gantt, an American engineer, and social scientist. Frequently used in project management, a Gantt chart provides a graphical illustration of a schedule that can be used to plan, coordinate and track tasks in a project.

Gantt charts can be simple versions created on graph paper or more complex automated versions created using project management applications such as Microsoft Project or Excel.

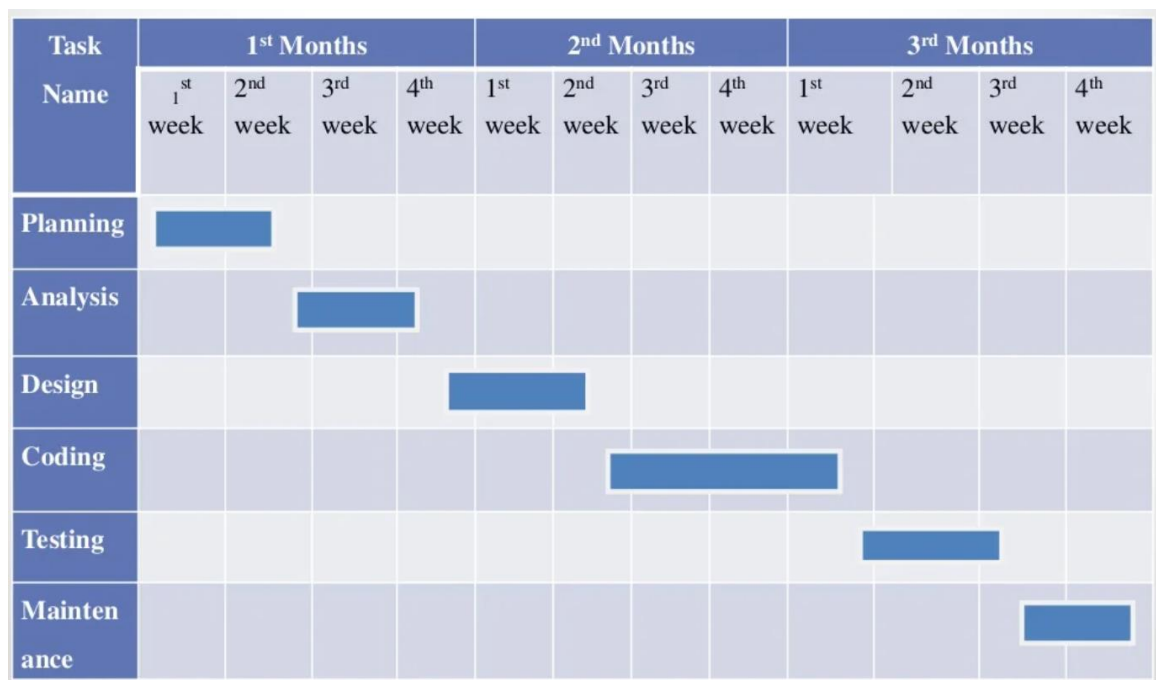
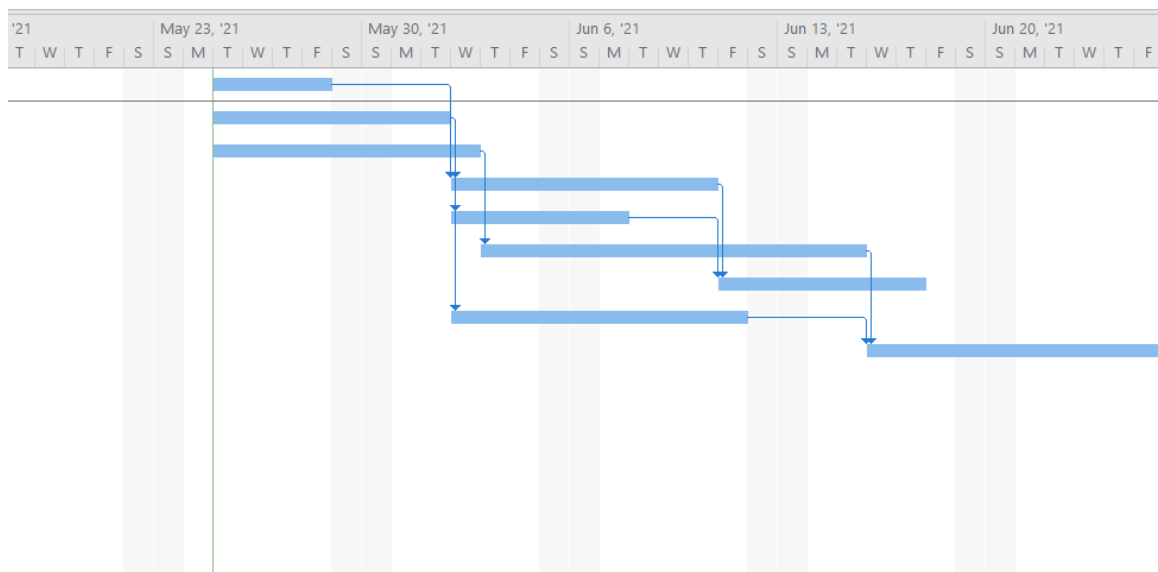

Figure: Gantt Chart

1. Draw a precedence network diagram by performing forward and backward passes. Also determine the critical path and completion date of the project. (Use the information given in the table)

Activity	Immediate Predecessor	Duration
A	None	4 days
B	None	6 days
C	None	7 days
D	A, B	7 days
E	B	4 days
F	C	9 days
G	D, E	5 days
H	B	8 days
I	F, H	8 days

Gantt Diagram



Network Diagram

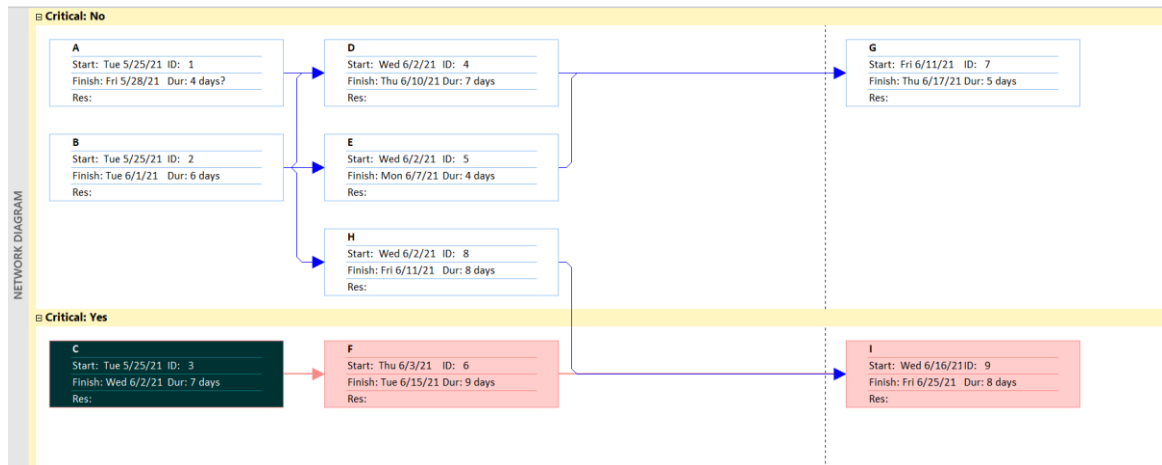

Property

LAB1 Properties

General Summary Statistics Contents Custom

Document contents:

- Scheduled Start: Tue 5/25/21
- Scheduled Finish: Fri 6/25/21
- Scheduled Duration: 24d?
- Work: 0h
- Cost: \$0.00
- % Complete: 0%
- % Work Complete: 0%

OK Cancel

2. Draw a precedence network diagram by performing forward and backward passes. Also determine the critical path and completion date of the project. (Use the information given in the table)

Activity	Immediate Predecessor	Duration
B		5 days
M	B	4 days
N	B	9 days
Q	B	15 days
A	M, N	1 day
F	N, Q	4 days
X	Q	9 days
C	Q	9 days
Y	A, F, X	9 days
S	F	6 days
J	X, F	5 days

Gantt Chart

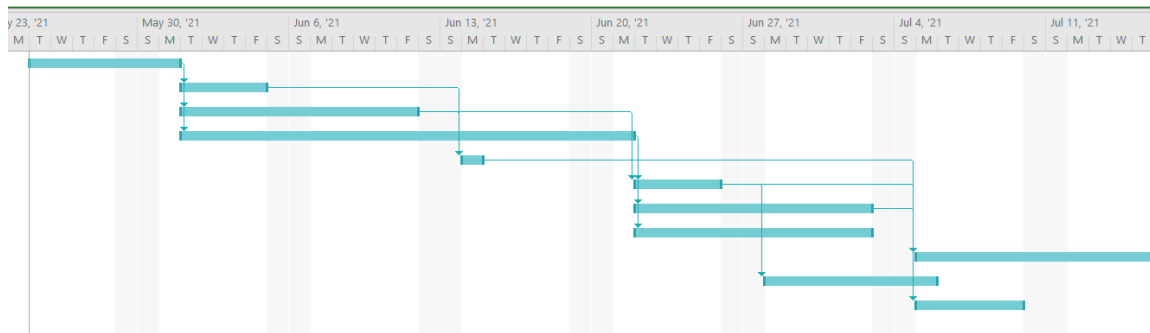

Network Diagram

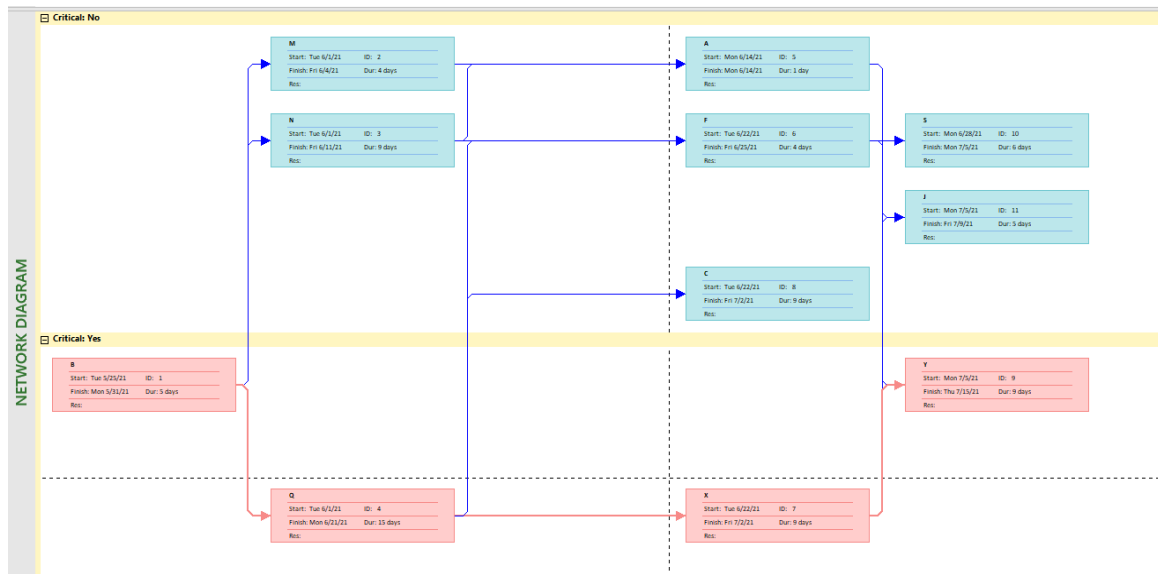

Property

LAB2 Properties

General Summary Statistics Contents Custom

Document contents:

- Scheduled Start: Tue 5/25/21
- Scheduled Finish: Thu 7/15/21
- Scheduled Duration: 38d
- Work: 0h
- Cost: \$0.00
- % Complete: 0%
- % Work Complete: 0%

OK Cancel

3. Draw a precedence network diagram by performing forward and backward passes. Also determine the critical path and completion date of the project. (Use the information given in the table)

Activity	Immediate Predecessor	Duration
A		1 day
B	A	8 days
C	A	4 days
P	A	7days
L	B	2 days
M	C	4 days
Q	P, C	4 days
N	P	9 days
Y	L, Q	5 days
F	M	10 days
J	Q	2 days

Gantt Chart

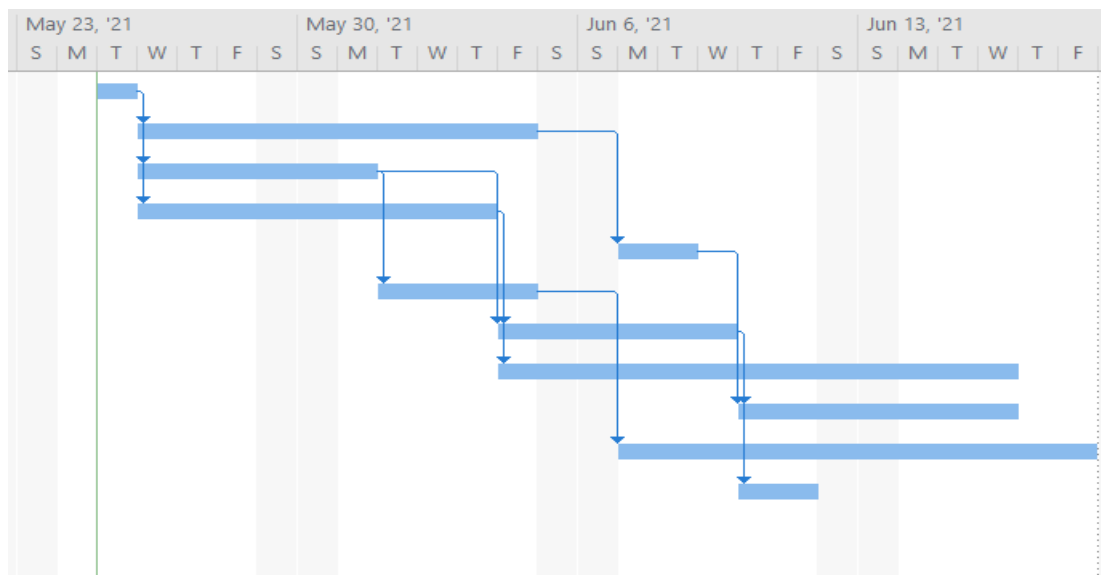

Network Diagram

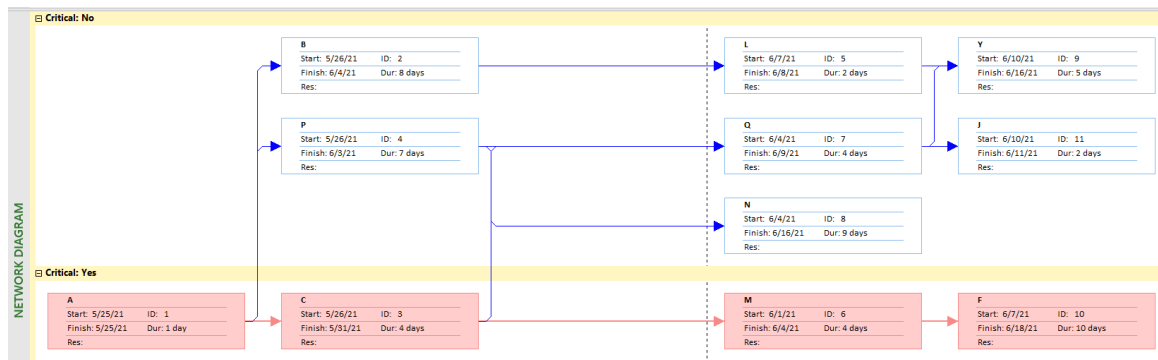

Property

LAB3 Properties

General Summary Statistics Contents Custom

Document contents:

- Scheduled Start: Tue 5/25/21
- Scheduled Finish: Fri 6/18/21
- Scheduled Duration: 19d
- Work: 0h
- Cost: \$0.00
- % Complete: 0%
- % Work Complete: 0%

OK Cancel

4. Draw a precedence network diagram by performing forward and backward passes. Also determine the critical path and completion date of the project. (Use the information given in the table)

Activity	Immediate Predecessor	Duration
A		2 days
B	A	4 days
C	A, B	7 days
P	A	4 days
X	B	5 days
Z	P, X	7 days
Y	Z	9 days

Gantt Diagram

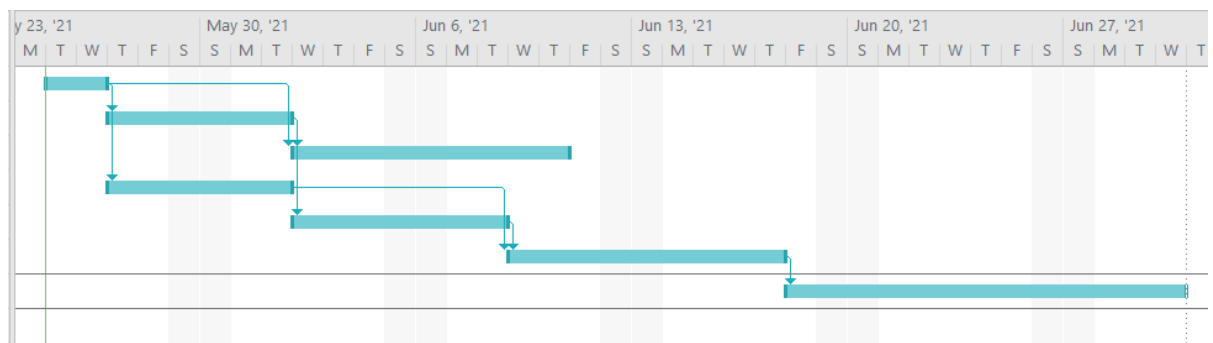

Network Diagram

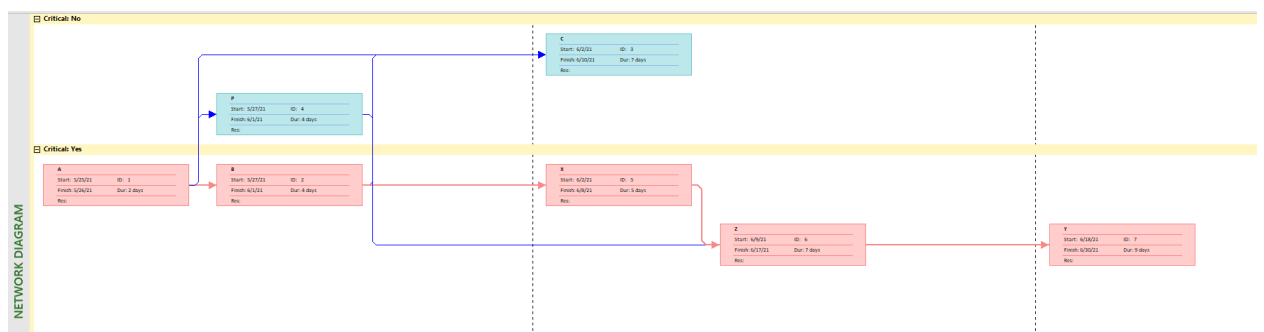

Property

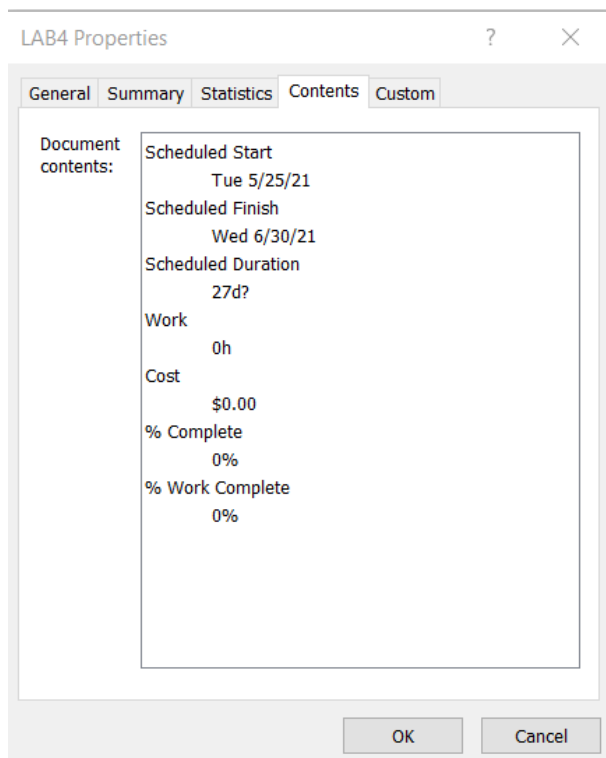

5. Consider the following table of information:

Activity	Duration(week)	Precedents
A	8	None
B	6	None
C	5	A
D	6	B
E	5	B
F	12	None
G	5	E, F
H	4	C, D

Draw the precedence network diagram and Gantt Chart using MS Project.

Gant Chart

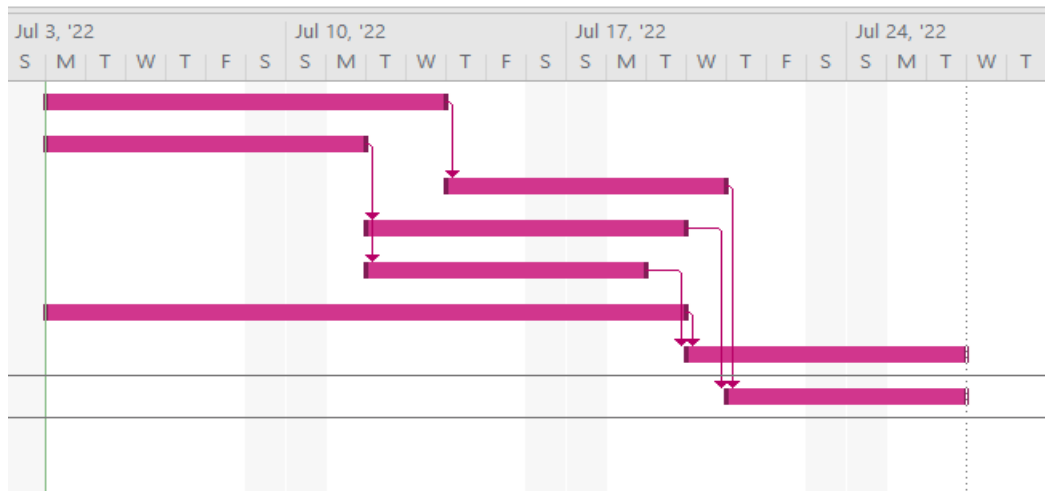

Network Diagram

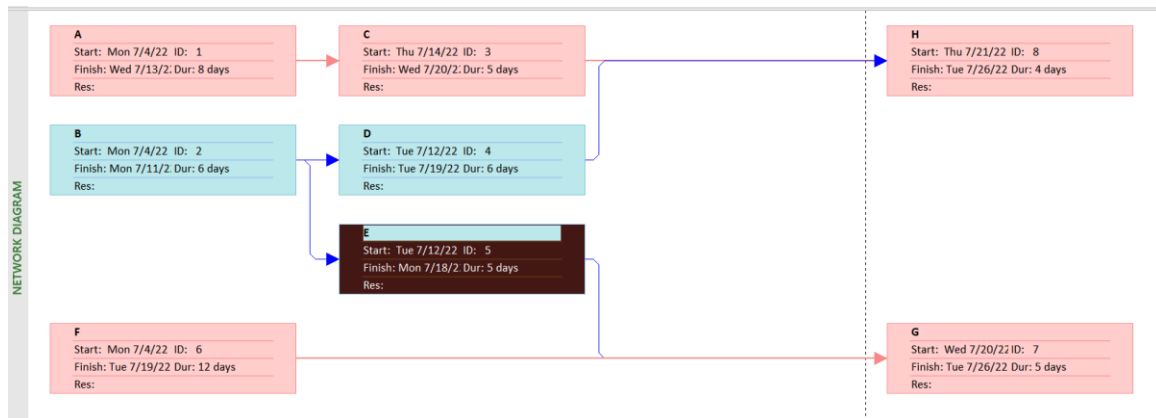

6. Consider the following table of information:

Activity	Duration	Depends on
A	5 days	-
B	1 day	-
C	2 days	A
D	3 days	A
E	2 days	A
F	3 days	C
G	4 days	D
H	2 days	B, E
I	1 days	H
J	1 days	F, G, I

Draw the precedence network diagram and Gantt Chart.

Gantt Chart

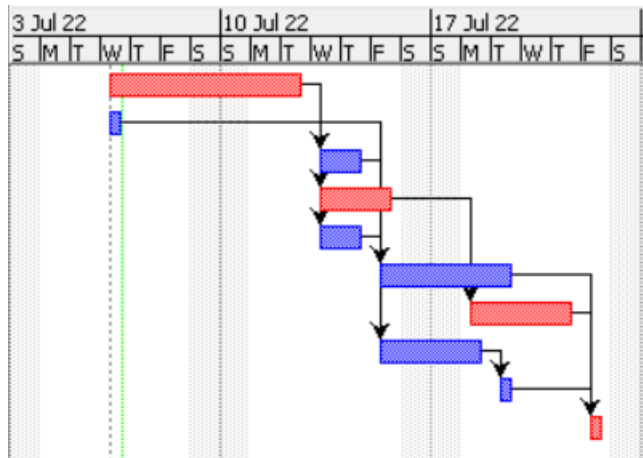

Network Diagram

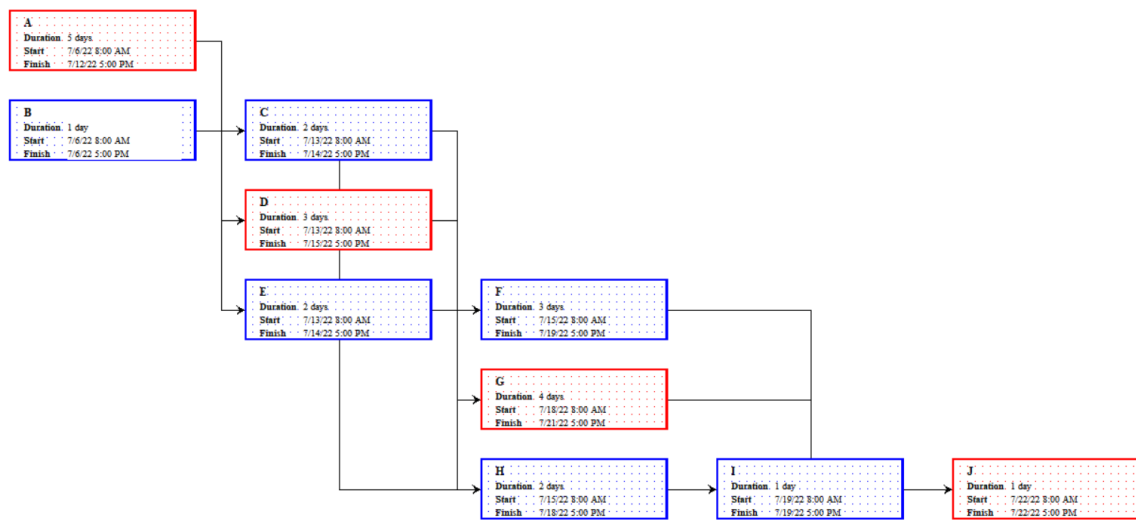

7. Consider the following table of information:

Activity	Duration(week)	Precedents
A	3	None
B	5	None
C	4	None
D	2	A
E	3	B
F	9	C
G	8	D,E
H	7	B
I	7	F,H

Draw the precedence network diagram and Gantt Chart.

Gantt Chart

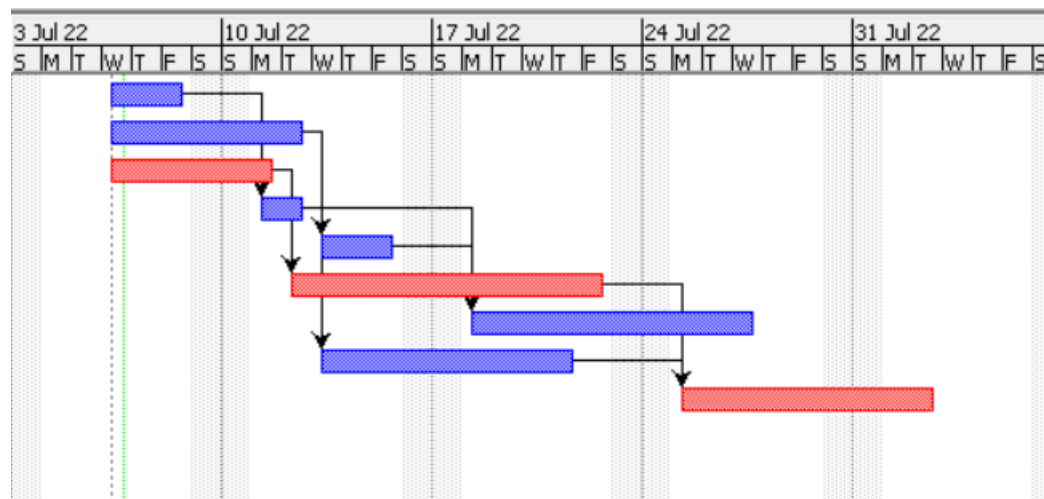

Network Diagram

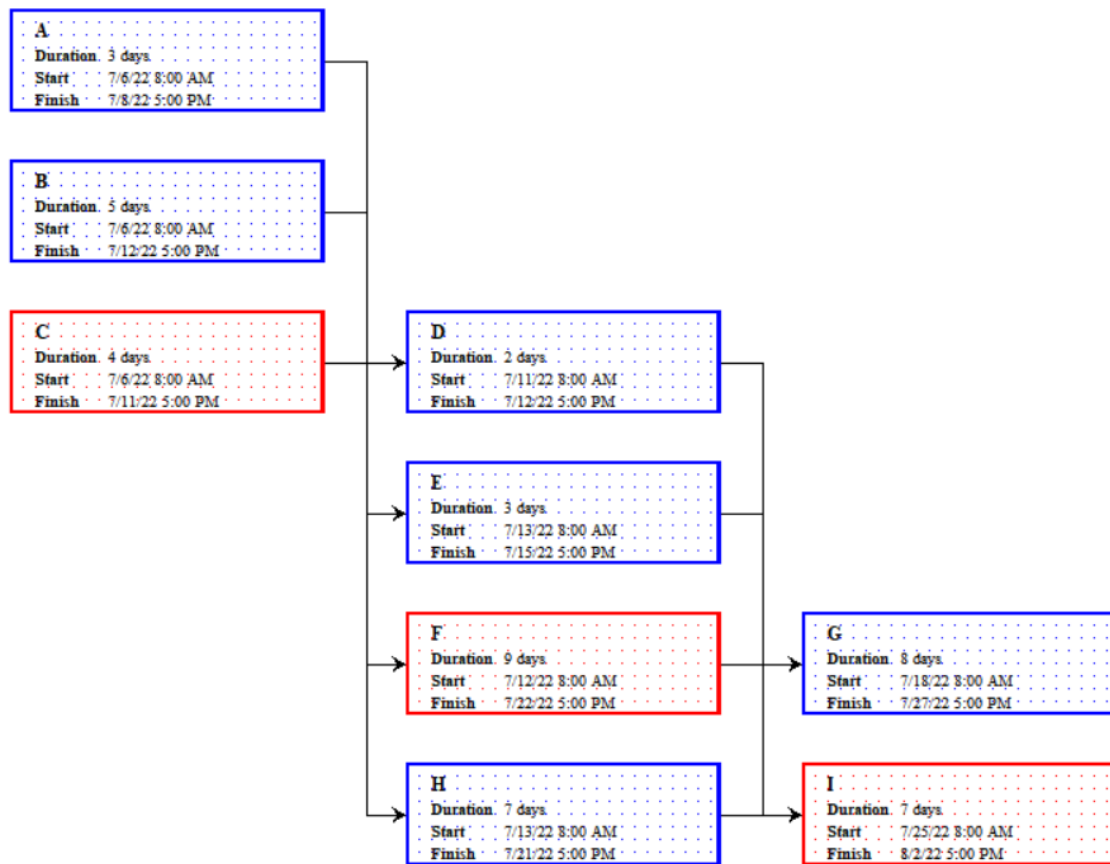

8. Consider the following table of information:

Activity	Duration(week)	Precedents
A	8	None
B	6	None
C	5	A
D	6	B
E	5	B
F	12	None
G	5	E, F
H	4	C, D

Draw the precedence network diagram and Gantt Chart.

Gantt Chart

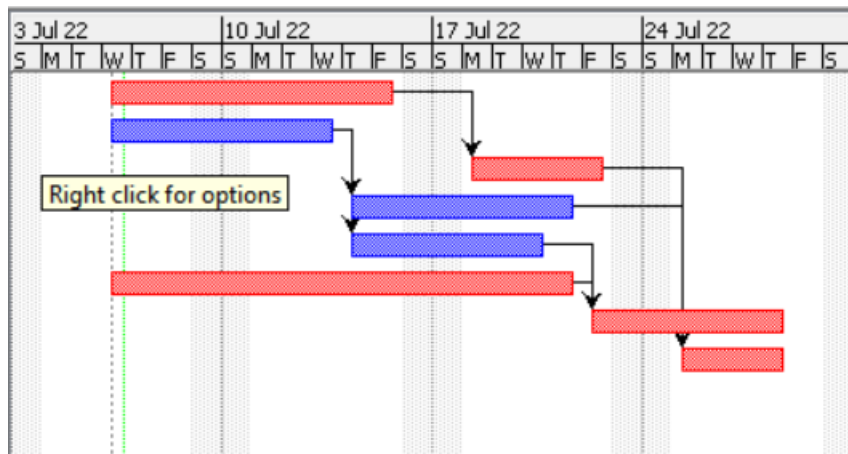

Network Diagram

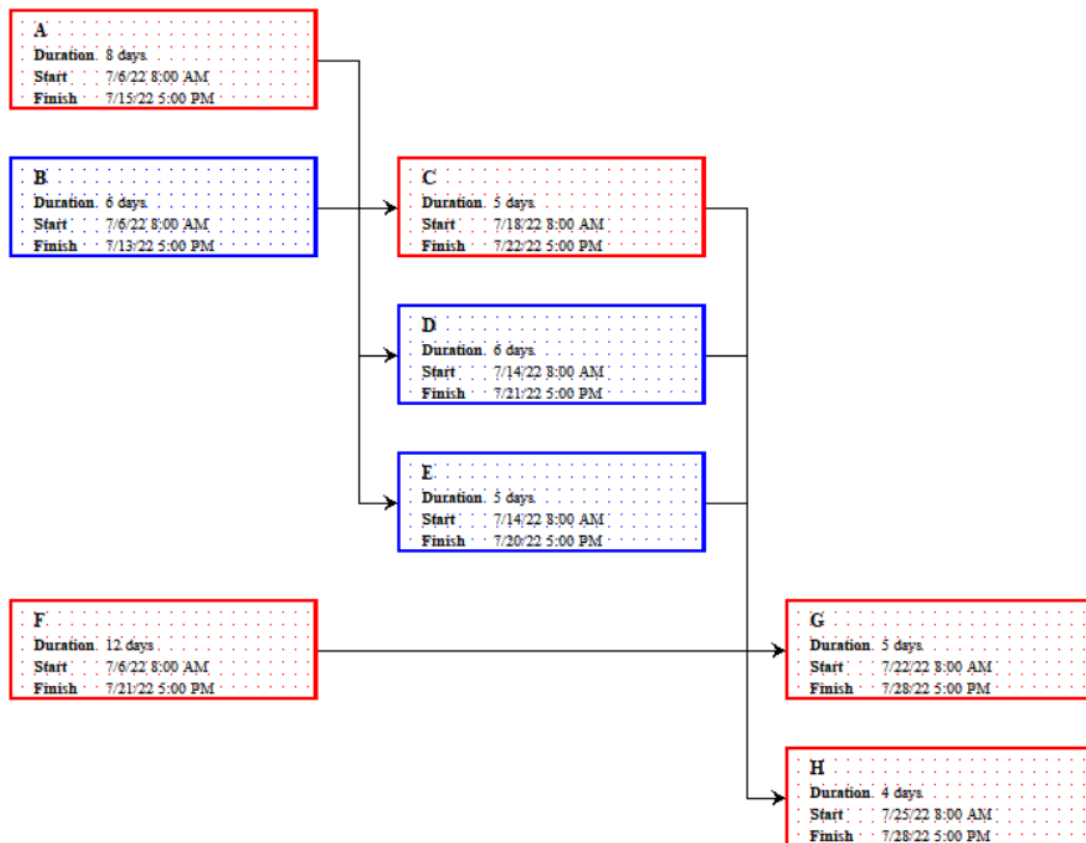

9. Consider the following table of information:

Activity	Duration(week)	Precedents
A	8	None
B	6	A
C	5	B
D	6	B
E	7	C
F	12	None
G	5	B, E
H	4	C,D
I	3	F

Draw the precedence network diagram and Gantt Chart.

Gantt Chart

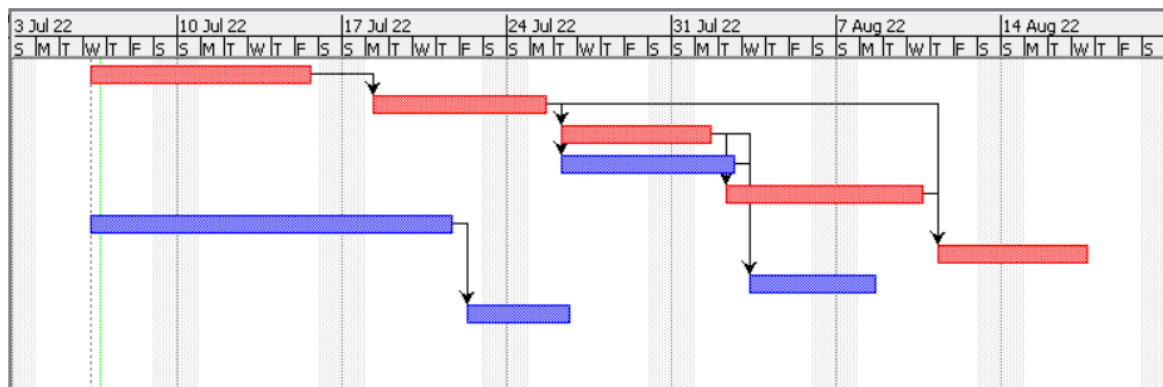

Network Diagram

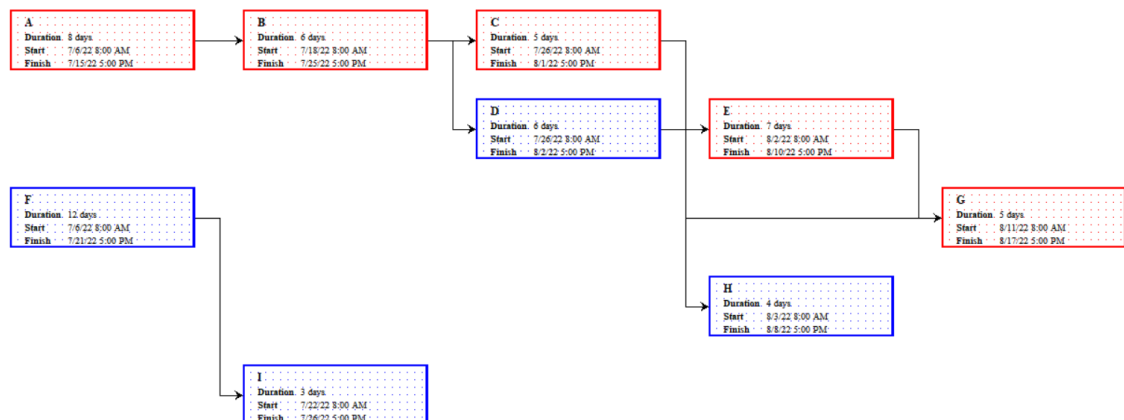

10. Consider the following table of information:

Activity	Predecessors (Days)	Duration
1	-	2
2	1	3
3	2	3
4	2	7
5	2	6
6	3,4	1
7	4,5	5
8	6,7	4
9	7	8
10	8,9	2

Draw the precedence network diagram and Gantt Chart.

Gantt Chart

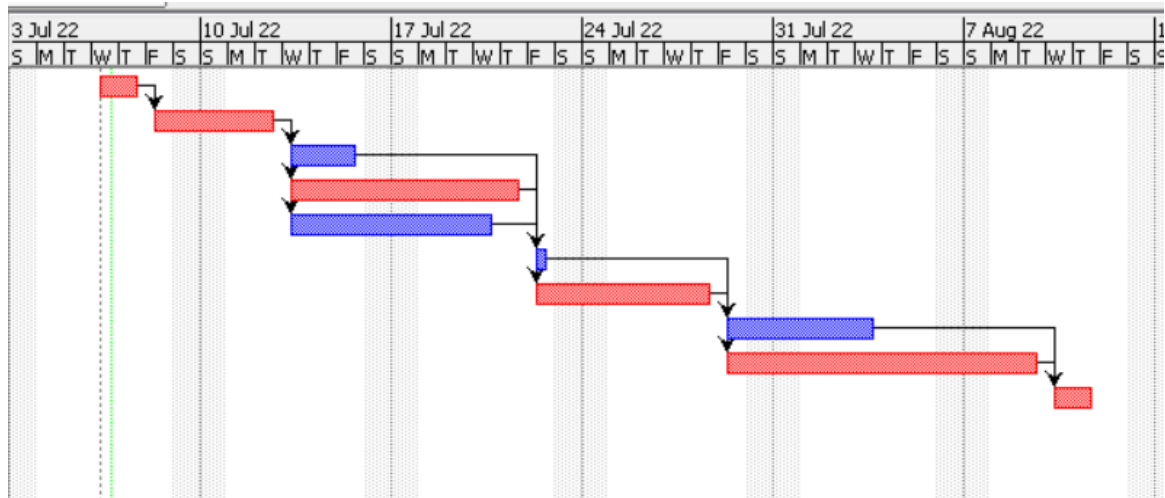

Network Diagram

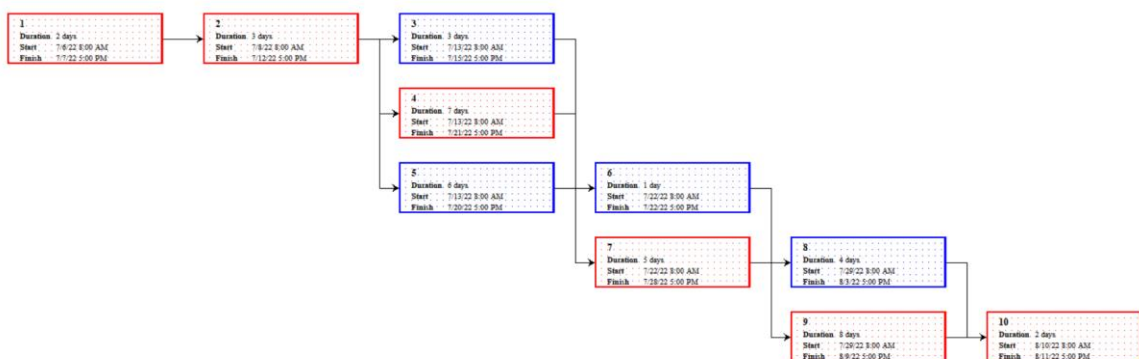

11. Consider the following table of information:

Task	Precedents	Duration (Days)
A		20
B	A	40
C	A	20
D	C, B	30
E	C	10
F	D, E	30
G	E	10
H	F, G	10

Draw the precedence network diagram and Gantt Chart.

Gantt Chart

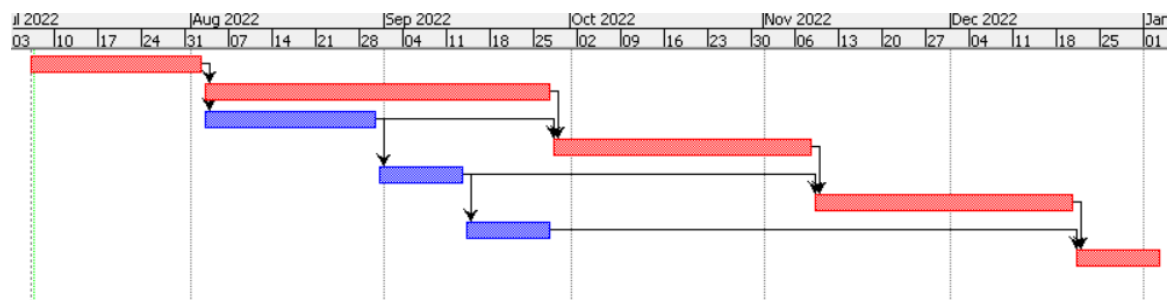

Network Diagram

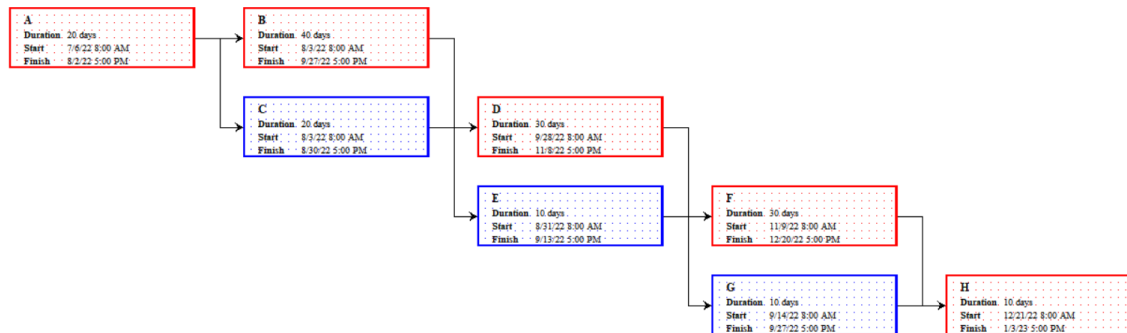

12. Consider the following table of information:

Activity	Precedence	Duration (months)
P	None	10
Q	None	4
R	P	3
S	Q	5
T	R	1
U	Q	5
V	None	4
W	T, V	6
X	R	7
Y	X, U	3

Draw the precedence network diagram and Gantt Chart.

Gantt Chart

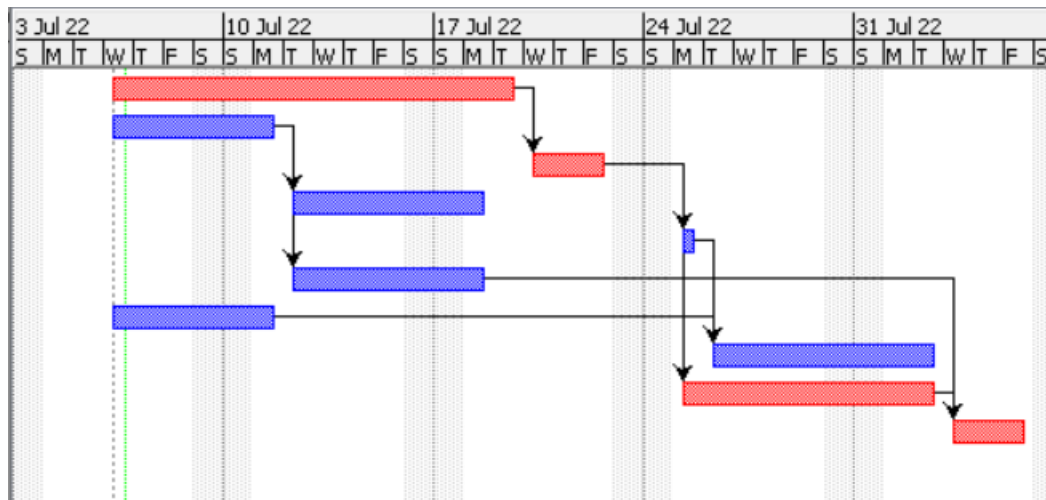

Network Diagram

